

# Clarksville Pike Urban Design Overlay at Fairview Center

Attachment to Ordinance No. BL  
as adopted on



# Acknowledgements

---

The staff of the Metropolitan Planning Department thanks the stakeholders who participated in the development of the Clarksville Pike Urban Design Overlay at Fairview Center. Special thanks are to the following persons and entities:

- Councilman Nick Leonardo for facilitation and participation
- Community meeting hosts: Greater Faith Missionary Baptist Church, Northwest Family YMCA, and Bordeaux Branch Library

## **Document Contact Information**

Planning Department staff provides consultations for developing within the Clarksville Pike Urban Design Overlay. Call (615) 862-7190 to schedule a meeting.

The Planning Department does not discriminate on the basis of race, color, national origin, gender, gender identity, sexual orientation, age, religion, creed or disability in admission to, access to, or operations of its programs, services, or activities. Discrimination against any person in recruitment, examination, appointment, training, promotion, retention, discipline or any other employment practices because of non-merit factors shall be prohibited. For ADA inquiries, contact Josie Bass, ADA Compliance Coordinator, at (615) 862-7150 or e-mail her at [josie.bass@nashville.gov](mailto:josie.bass@nashville.gov). For Title VI inquiries, contact Human Relations at (615) 880-3370. For all employment-related inquiries, contact Human Resources at (615) 862-6640.

# Table of Contents

---

<b>Section I: Introduction</b> . . . . .	<b>5</b>	<b>Section IV: Sign Standards</b> . . . . .	<b>31</b>
History and Overview . . . . .	6	Administration . . . . .	32
Intent and Goals . . . . .	6	General Requirements . . . . .	33
Location and Site Description . . . . .	7	Permitted Sign Types . . . . .	34
		Building Signage	
		Ground Signage	
<b>Section II: Application of Standards</b> . . . . .	<b>9</b>		
How to Use this Document . . . . .	10		
Compliance . . . . .	11		
Development Review Process and Modifications. . . . .	12		
<b>Section III: Design Standards</b> . . . . .	<b>15</b>		
Streets and Frontages . . . . .	16		
Street Types			
Frontage			
Regulating Plan			
<b>Building Types</b> . . . . .	<b>18</b>		
Residential (One- & Two-Family)			
Residential (Multifamily)			
Mixed-Use or Non-Residential			
Civic			
<b>Bulk Standards</b> . . . . .	<b>22</b>		
Active Use			
Build-to Zone			
Facade Width			
<b>Architectural Standards</b> . . . . .	<b>23</b>		
Glazing			
Massing			
Materials			
Canopies and Awnings			
<b>Access and Parking Standards</b> . . . . .	<b>26</b>		
Parking Location			
Vehicular/Pedestrian Conflict			
Vehicular Drop-off			
Parking Structures			
Cross Access and Joint Access			
Drive-Through Lanes			
<b>Landscaping and Screening Standards</b> . . . . .	<b>28</b>		
Surface Parking Lots			
Service and Utility Areas			
Fences and Walls			

---

This page left intentionally blank

# Section I: Introduction

History and Overview  
Intent and Goals  
Location and Site Description

# Section I: Introduction

## Introduction

---

### History and Overview

The Clarksville Pike Urban Design Overlay (UDO) at Fairview Center (hereafter referred to as the “Clarksville Pike UDO” or the “UDO”) is located in the Bordeaux-Whites Creek Community, an area in northwestern Davidson County. The community area has abundant natural resources along with a mixture of suburban and rural uses and institutions. The UDO is on a segment of the Clarksville Pike Corridor that extends from West Hamilton Avenue to Kings Lane. The UDO implements the community vision set forth in the Bordeaux-Whites Creek Community Plan to achieve cohesive development along the Clarksville Pike Corridor.

The Bordeaux–Whites Creek Community Plan was first adopted by the Metro Planning Commission in August 1992, after working with a Citizens’ Advisory Committee. The community’s second plan update was adopted in 2003 after community participation in workshops. In 2004, a detailed design plan was completed for the lower section of Clarksville Pike to guide development and redevelopment to create walkable, mixed use communities in a more compact pattern. The most recent update to the Community Plan occurred in June 2015 with the Metro Planning Commission approval of NashvilleNext, the long-range plan for growth, development and preservation in Nashville and Davidson County.

The Growth and Preservation Concept Map, included in NashvilleNext, reflects Nashvillians’ desires for how Nashville should grow in the future. The Clarksville Pike UDO area is identified as a Tier One center on the map. These centers build on existing commercial areas, encouraging them to evolve into active, mixed-use places serving as a neighborhood or community gathering place. Centers are anticipated to become pedestrian-friendly areas with frequent transit service that contain a mix of homes, shops, jobs and parks, as well as services, schools and cultural amenities. This aligns with the concept laid out in the detailed design plan.

### Intent and Goals

The purpose of the UDO is to provide a framework for a consistent development pattern and an harmonious streetscape along Clarksville Pike that includes high quality and pedestrian friendly design elements. The UDO envisions attractive development that is consistent in physical form to contribute to a complete built environment while accommodating a mix of uses and multiple modes of transportation. The UDO focuses on broad design standards while emphasizing best practices for quality urban design.

The Intent and Goals are the result of the public planning process. The intent of the UDO is to improve urban design by addressing issues related to development such as buildings and lots, parks and open space, vehicular circulation, bicycle and pedestrian circulation, signage, transit, access, parking, landscaping and buffering. The goals of the UDO are as follows:

- Restore value to Clarksville Pike through appropriate streetscape improvements, building orientation and massing.
- Encourage a high quality (function and aesthetic) suburban context through the design of architectural and landscaping components.
- Encourage a high level of pedestrian-generating activity along streets and a pedestrian friendly environment.
- Encourage an appropriate mix of compatible uses consistent with the scale and character of the corridor.
- Encourage a balance of transportation options for pedestrians, bicycles, vehicles and transit by managing the impact of the automobile and incorporating efficient access for different modes of transportation.
- Integrate signage as part of the overall building design and manage its visual impact along the corridor.

# Section I: Introduction

## Location

The Clarksville Pike UDO area is primarily a suburban mixed use corridor located approximately five miles northwest of downtown Nashville along Clarksville Pike.



Bordeaux-Whites Creek  
Community Plan Area

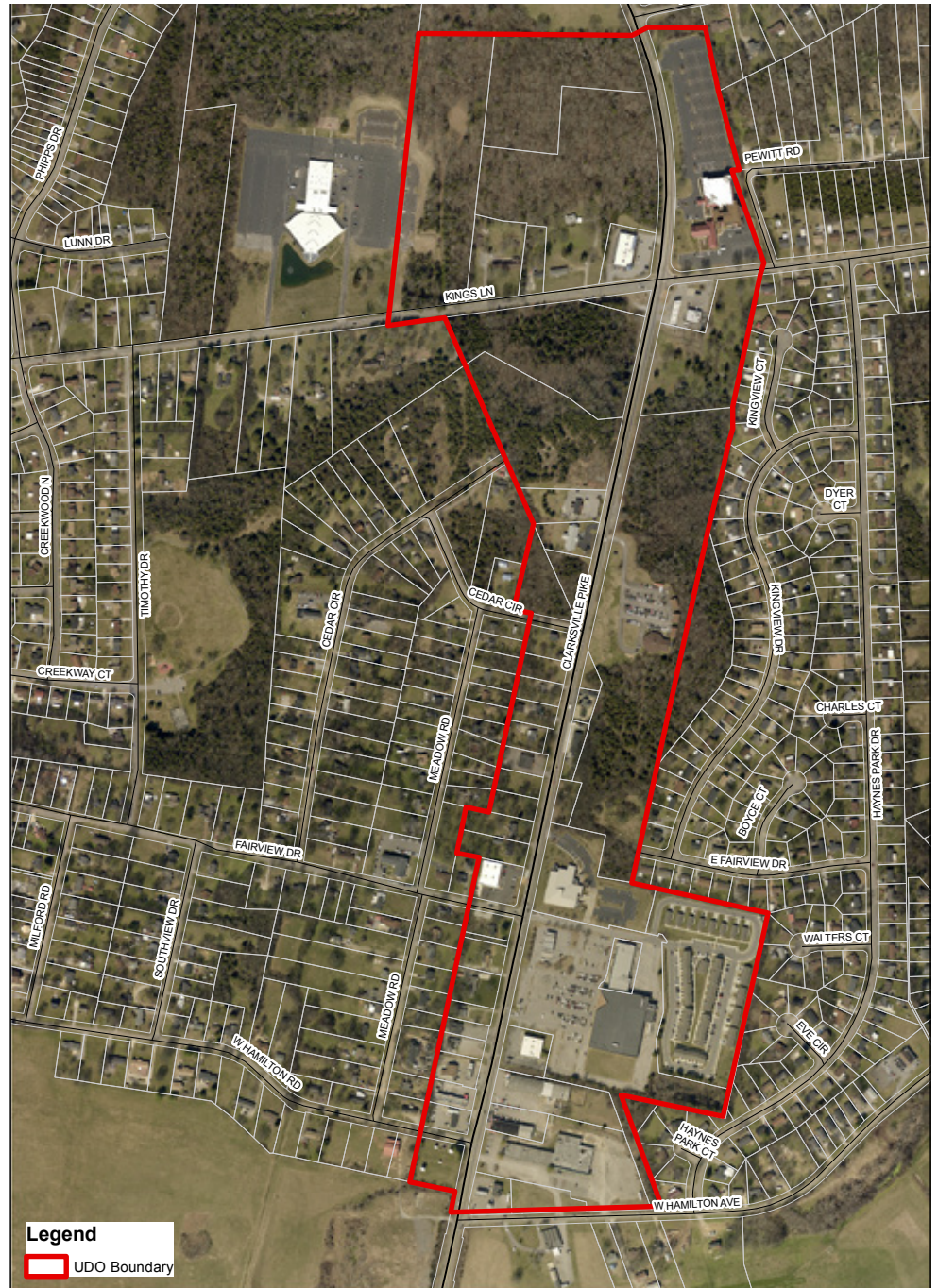

0 500 1,000 2,000 Feet



This page left intentionally blank



# Section II: Application of Standards

How to Use this Document  
Compliance  
Development Review Process and Modifications

# Section II: Application of Standards

## How to Use this Document

---

The design standards established in the Clarksville Pike Urban Design Overlay (UDO) at Fairview Center are intended to guide future development in a manner that addresses strategies for site design including placement, massing and orientation of buildings, architectural treatment, landscaping and screening, general access and parking, and signage.

The standards established in this document vary from the underlying base zone district standards for the properties in the UDO. In some instances, desired standards that are beyond the authority of the zoning ordinance accompany the goals and objectives. These desired standards pertain to areas for which Metropolitan Government exercises final authority over design, construction and operation of facilities, such as public rights-of-way and stormwater detention and conveyance. The incorporation of these standards into any final development construction plans will depend on Metropolitan Government review for consistency with policies, laws, and related standards of various departments.

This document is to be used by developers, property owners, government officials, residents, and any individual who is interested in development or redevelopment of any property located within the UDO boundary.

### Urban Design Overlay

An Urban Design Overlay (UDO) is a zoning tool that requires unique physical design standards for development or redevelopment within a designated area that would otherwise not be ensured by the standard provisions of the zoning regulations. A UDO can modify base zoning standards such as setbacks, building height, floor area ratio, and parking per the provisions outlined in Section 17.36.320 of the Zoning Code. All provisions are regulatory in nature and have the same force and effect as the zoning regulations of the Metro Code. Any final plans submitted for approval under a UDO will be reviewed for adherence to its provisions and to the provisions of the base zoning that are not varied by the UDO.

### Overlapping Plans

Within the UDO boundary area, there may exist other regulations and design guidelines intended to work in conjunction with the UDO. Property owners and developers should consult with all departments and agencies during the development process to address any and all rules, regulations and policies. Property owners should consult with Metro Planning and Public Works to make the necessary improvements to the streetscape in accordance with the Major and Collector Street Plan and the Strategic Plan for Sidewalks and Bikeways and Title 17.20.120 Provision of sidewalks.

Finally, there may be some properties within the UDO boundary zoned Specific Plan (SP) or within a Planned Unit Development (PUD).

- If a property is zoned Specific Plan, then all standards contained with the Specific Plan shall apply and the UDO standards would apply for any standard not addressed in the SP.
- If a property has a Planned Unit Development Overlay, then the standards of the PUD shall apply and the UDO standards would apply for any standards not addressed in the PUD.

## Section II: Application of Standards

### Compliance

---

All provisions of the Metro Zoning Code shall apply, unless otherwise addressed by the Clarksville Pike UDO standards. The UDO standards shall apply as follows:

#### **New Development**

- Full Compliance with all standards of the UDO.

#### **An addition to the square footage of an existing building:**

- The addition shall be in compliance with applicable standards of the UDO and shall not increase any degree of non-conformity.

#### **A new structure on a lot with existing building(s):**

- The new structure shall be in compliance with applicable standards of the UDO and shall not increase any degree of non-conformity.

#### **Signage Compliance:**

- New signs shall comply with all Signage Standards.
- Existing legally non-conforming signs shall not increase the degree of non-conformity.
- Existing signs of a type prohibited (pole-mounted, etc.) shall be permitted to only replace existing sign panels. Panels installed must be compliant with the illumination standards set forth by the UDO.

#### **Inclusionary Housing**

Applicants shall provide two scenarios with proposed residential development. One scenario shall illustrate the residential development entitlements provided by the underlying zoning at the time this UDO was adopted, and the second scenario shall illustrate the residential development entitlements permitted by the UDO standards.

If residential entitlements provided by the UDO standards are greater and the proposed development involves five or more residential rental units, affordable or workforce housing shall be recognized as set forth in Ordinance Nos. BL2016-133, and BL2016-342, which authorizes Metro grants to offset the provision of affordable or workforce housing units.

If the underlying zoning for the property has changed since the adoption of this UDO, applicants shall provide a third scenario showing residential entitlements provided by the current zoning with the UDO applied. If the proposed development involves five or more residential rental units, affordable or workforce housing shall be recognized as set forth in Ordinance Nos. BL2016-133, and BL2016-342, which authorizes Metro grants to offset the provision of affordable or workforce housing units, due to residential development entitlements gained through the underlying zone change.

## Section II: Application of Standards

### Development Review

---

#### Process

Applicants are encouraged to contact Metro Planning Staff early on in the design and development process for a pre-application meeting. Where physical constraints exist on the site, Planning Staff will review alternate design solutions that achieve the intent of the UDO.

Prior to applying for a building permit, applicants shall apply for a UDO “Final Site Plan” application with the Planning Department. The “Final Site Plan” shall be reviewed and approved by all departments prior to the issuance of a building permit.

Following the approval of the Final Site Plan, a Final Plat may be required to establish lots, rights-of-way and easements.

#### Modifications

Any standard within the Clarksville Pike UDO may be modified, insofar as the intent of the standard is being met, the modification does not reduce the urban design quality for the neighborhood as a whole, and the modification does not impede or burden existing or future development of adjacent properties.

Modifications may be approved by Planning Staff or the Planning Commission prior to or concurrent with a final site plan as follows:

- Minor modifications – deviations of 20% or less, or minor deviations in non-numerical standards – may be approved by Planning Staff or the Planning Commission.
  - Any determination made by Planning Staff may be appealed to the Planning Commission.
- Major Modifications – deviations of more than 20%, or major deviations from non-numerical standards may be approved by the Planning Commission.

#### Variances and Special Exceptions

Variances and special exceptions that are not specifically for standards of the Clarksville Pike UDO shall follow the procedures of the applicable chapters of the Metro Zoning Code. Variances and special exceptions shall not be applicable to the height standards of the UDO.

Standards specific to the Clarksville Pike UDO may be modified based on the Modifications section of this document.

# Section II: Application of Standards

## Development Review Flow Chart

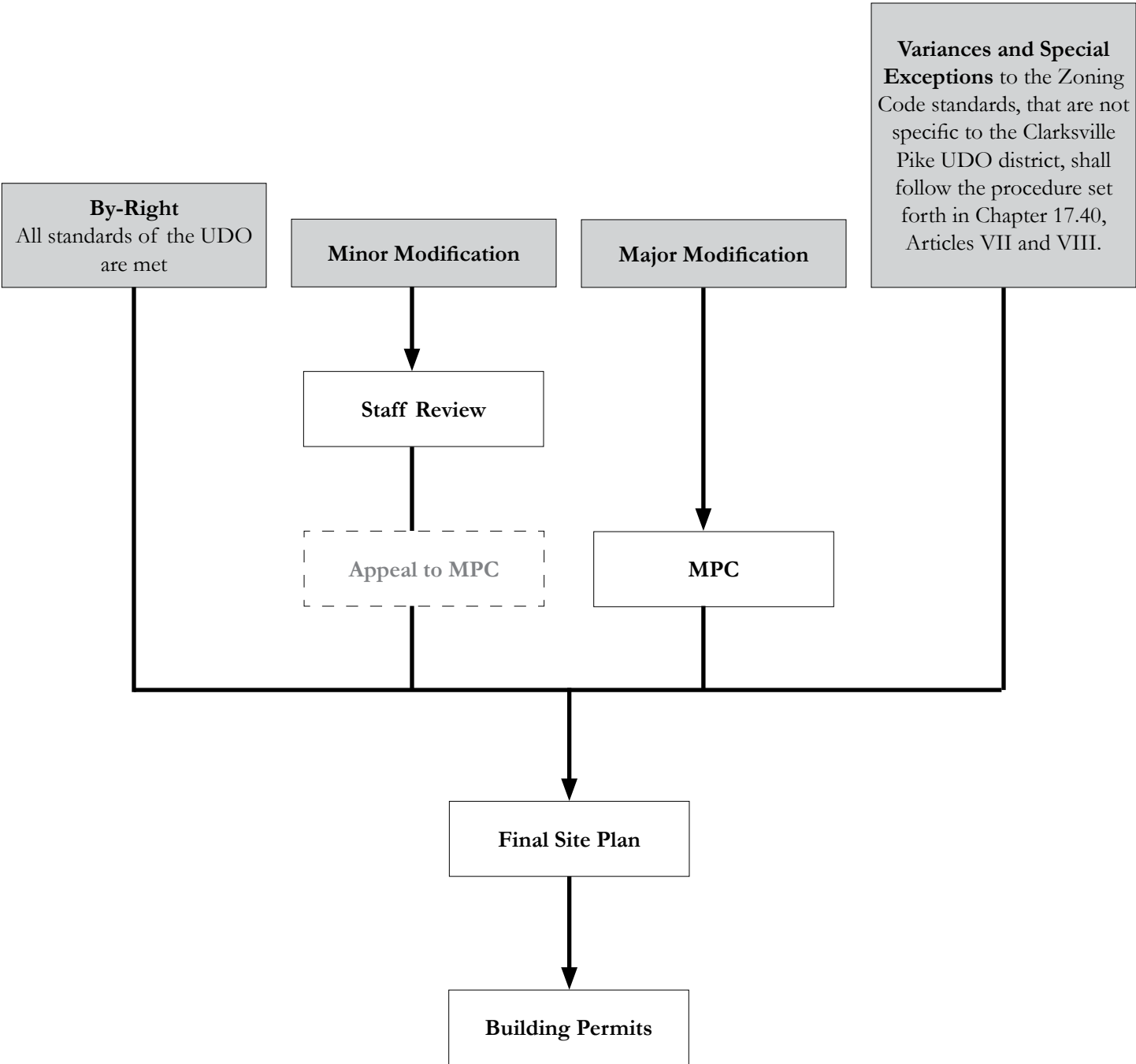

This page left intentionally blank

# Section III: Design Standards

Streets and Frontages  
Building Types  
Bulk Standards  
Architectural Standards  
Access and Parking Standards  
Landscaping and Screening Standards

# Section III: Design Standards

## Streets and Frontages

### Major and Collector Street Plan

The streetscape along Clarksville Pike shall be improved with the standards specified by the Major and Collector Street Plan (MCSP). Local Streets shall meet Local Street standards.

### Street Types

The Clarksville Pike UDO uses Street Types as an urban design and organizing tool. All existing streets are classified on the Regulating Plan as Primary or Secondary. All future streets shall be classified as Secondary Streets, unless designated by the MCSP.

- **Primary Streets** provide high levels of pedestrian, vehicular, and transit activity. Pedestrian comfort on these streets is of the highest importance. The sidewalk should provide room for features such as trees, benches, trash and recycling receptacles, and bicycle parking as well as a clear travel path for pedestrians. Active uses – residential, retail, restaurant or office – lining parking structures on the ground floor of buildings, and restricted vehicular access enhance the pedestrian experience. On corner lots, vehicular access to parking lots, parking structures, and “back of house” functions are strongly discouraged from Clarksville Pike.
- **Secondary Streets** are small neighborhood streets which may be residential, commercial, or mixed-use in character. Care should be taken to make these streets as pedestrian-friendly as possible while accommodating loading and access needs. On corner lots, vehicular access to parking lots, parking structures and “back of house” functions is allowed. When “back of house” functions are located on Secondary Streets, significant efforts should be made to reduce the impact on the sidewalk and adjacent properties

Vehicular access from public streets shall be considered in the following order: Secondary Streets and then Primary Streets as approved by Metro Departments. Where alleys exist, they shall be prioritized for access and loading.

### Frontage

Frontage is the specific way in which the building face addresses the street. Buildings shall front onto a public right-of-way (excluding alleys) or open space with a pedestrian way.

### Principal and Minor Frontages:

- Every property shall establish one Principal Frontage.
- When a property fronts more than one street type, the following priority shall be given when establishing the Principal Frontage: Primary Street then Secondary Street.
- When a property fronts multiple Primary Streets, all shall be treated as the Principal Frontages.
- When a property fronts on only a Secondary Street, it shall be treated as the Principal Frontage.
- Entrances
  - All buildings shall have at least one pedestrian entrance on the Principal Frontage; this may be access to a lobby shared by individual tenants.
  - When a property has two Principal Frontages, the pedestrian entrance shall be located on the Clarksville Pike frontage, or at the corner.
  - Corner entrances are appropriate on corner lots.

### Open Space Frontage:

- Facade width and active use requirements shall apply to these frontages the same as a street frontage.
- All buildings fronting open space shall have a minimum of one primary entrance on the open space.

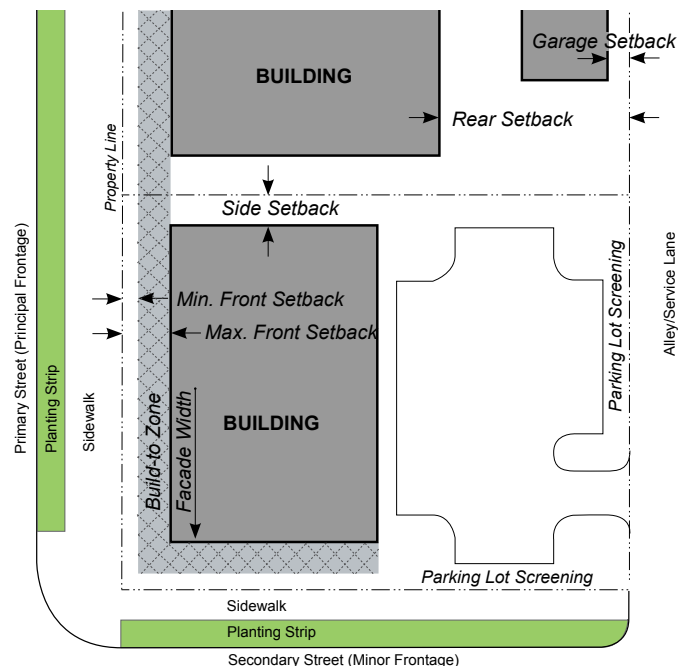

### Frontage, Build-to Zone, and Facade Width



# Section III: Design Standards

## Regulating Plan

The Regulating Plan is the guiding map for the implementation of the UDO. The regulating plan shows the sub-districts and street types that govern the development standards for each property.

### Sub-District 1: Mixed-Use Corridor

A moderately intense “main street” where mixed use development is prominent but is moderately scaled.

Permitted building types: Mixed-Use/Non-Residential, Residential (Multifamily), Civic

### Sub-District 2: Residential Corridor

Development preserves the residential character of the area while providing opportunity for an evolving pattern.

Permitted building types: Residential (One- & Two-family), Residential (Multifamily), Civic

### Sub-District 3: Residential Neighborhood

Development provides housing choice and creates transitions between intense commercial land uses, and less intense residential neighborhoods.

Permitted building types: Residential (One- & Two-family), Residential (Multifamily)

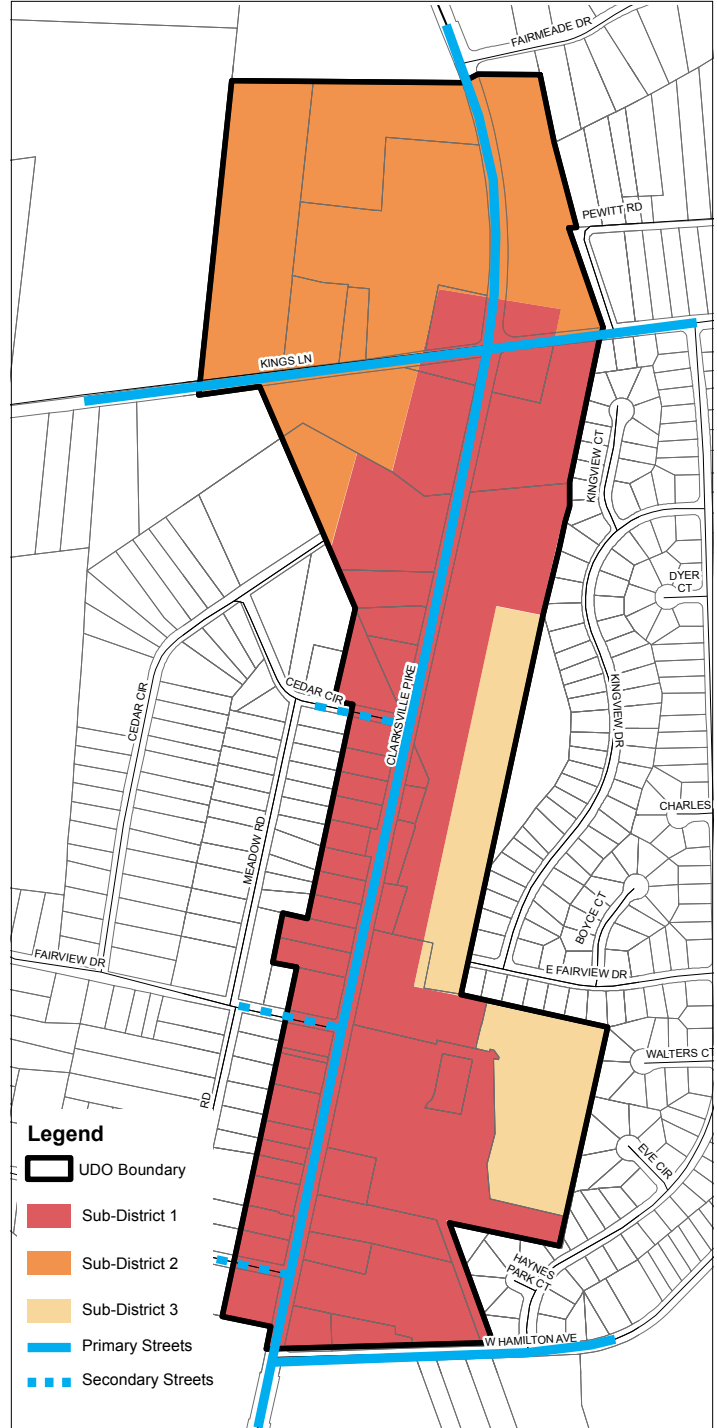

# Section III: Design Standards

## Building Type - Residential (One- & Two-Family)

### Description

A structure exclusively for residential use and with a maximum of two dwelling units. Typical forms are a single-family house or a duplex (attached or detached).

### General Provisions

- Building height shall be measured to the top of parapet or principal roof ridge from the average elevation of the front setback.
- Basements are not considered stories for the purpose of determining building height in stories.



### Bulk Standards

<b>A</b>	Build-to Zone <sup>1</sup>	20' Min - 40' Max
<b>B</b>	Side Setback (min)	Per base Zoning
<b>C</b>	Rear Setback (min)	Per base Zoning
<b>D</b>	Building Height (max)	3 stories in 45'
<b>E</b>	Raised Foundation on Principal Frontage(s)	1.5' Min - 3' Max

<sup>1</sup>Balconies, porches, stoops and other architectural features may encroach up to 8' beyond front setback. Steps may encroach to the front property line.

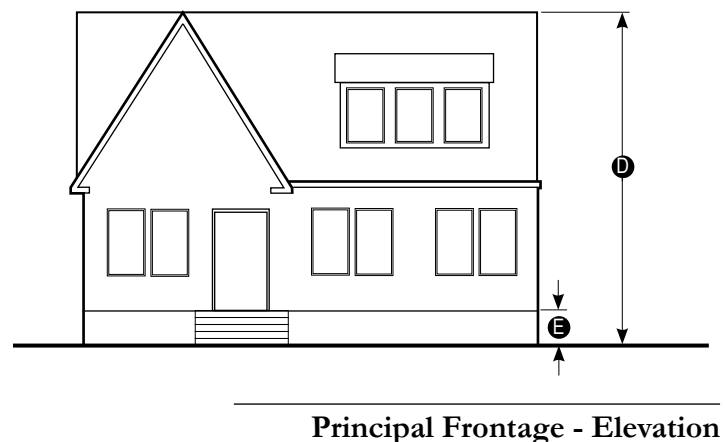
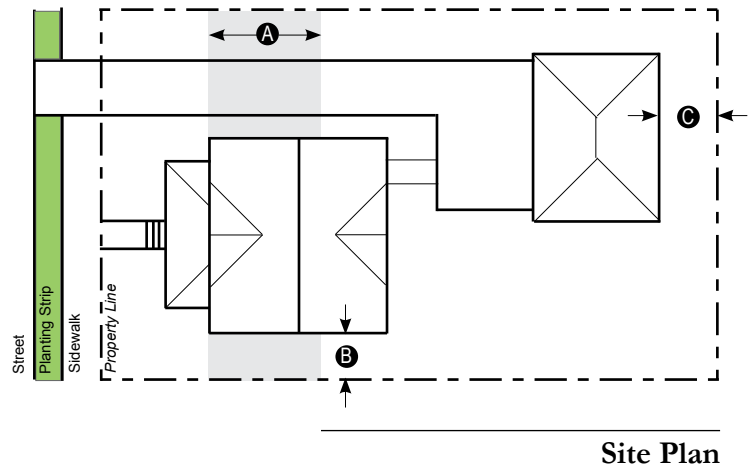

# Section III: Design Standards

## Building Type - Residential (Multifamily)

### Description

A structure exclusively for residential use and with a minimum of three dwelling units. Various forms may range from cottage developments to townhouses and stacked flat buildings.

### General Provisions

- Building height shall be measured to the top of parapet or principal roof ridge from the average elevation of the front setback.
- Basements are not considered stories for the purpose of determining building height in stories.
- Garage doors shall not be located on the principal frontage.



### Bulk Standards

<b>A</b>	Build-to Zone <sup>1,2</sup>	10' Min - 80' Max
<b>B</b>	Side Setback (min) <sup>3</sup>	Per base Zoning; Townhouse end unit 5' min
<b>C</b>	Rear Setback (min)	Per base Zoning
<b>D</b>	Facade Width (min)	50% of buildable lot frontage; 50' Min if lot frontage > 100'
<b>E</b>	Building Height (max)	3 stories in 45'
<b>F</b>	Raised Foundation on Principal Frontage(s)	1.5' Min - 3' Max

<sup>1</sup>Balconies, porches, stoops and other architectural features may encroach up to 5' beyond front setback, but all such encroachments combined shall not exceed 60% of the facade width. Steps may encroach to the front property line.

<sup>2</sup>For shared court and laneway houses, build-to zone may vary for non-street frontage buildings.

<sup>3</sup>Side setback between townhouse units may be 0 feet.

**SHARED COURT BUILDING TYPE:** For housing types such as cottage courts, townhouse courts, and courtyard flats that front onto a common open space, the following shall apply:

- Dwellings shall abut a minimum of two sides of the central open space.
- The width of the open space, measured between buildings, shall be a minimum 75% of the tallest building height, measured to the bottom of the eave or top of parapet.
- Parking, driveways, and detention areas shall not be located within the central open space. Exceptions may be permitted for stormwater elements such as rain gardens and bioswales when incorporated as a design element.
- Parking areas adjacent to the open space shall be screened.
- Interior sidewalks, a minimum of 5 feet wide, shall connect all units to the sidewalks at the street frontage and the parking areas.

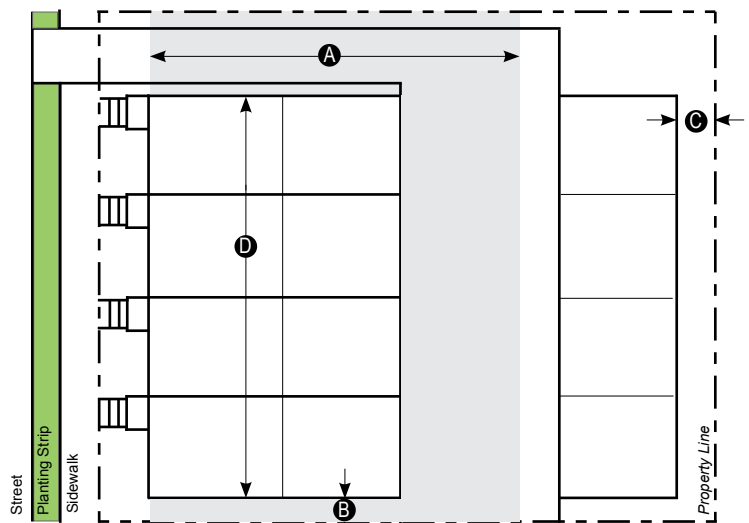

Site Plan

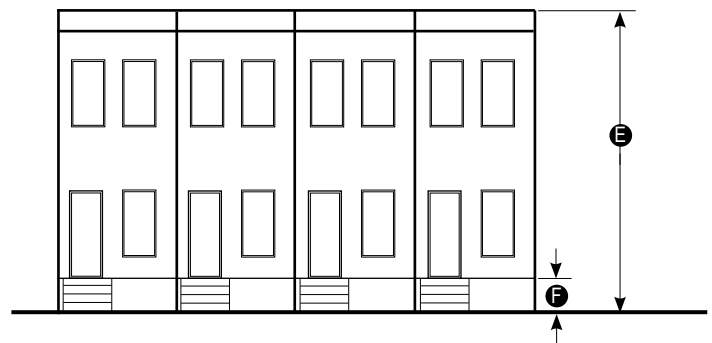

Principal Frontage - Elevation

# Section III: Design Standards

## Building Type - Mixed-Use or Non-Residential

### Description

A structure with a mix of uses or a non-residential use. Such a structure may provide a mix of commercial, office and/or residential uses, with the non-residential use on the ground floor.

### General Provisions

- Building height shall be measured to the top of parapet or principal roof ridge from the average elevation of the front setback.
- Basements are not considered stories for the purpose of determining building height in stories.



### Bulk Standards

<b>A</b>	Build-to Zone <sup>1</sup>	5' Min - 80' Max
<b>B</b>	Side Setback (min)	Per base Zoning;
<b>C</b>	Rear Setback (min)	Per base Zoning
<b>D</b>	Facade Width (min)	50% of buildable lot frontage; 50' Min if lot frontage > 100'
<b>E</b>	Building Height (max)	3 stories in 45'
<b>F</b>	First Floor Height (min)	One-story bldg: 16' Min Multi-story bldg: 14' Min
<b>G</b>	Upper Floor(s) Height (min)	10' floor-to-floor

<sup>1</sup>Exceptions may be made for up to 20' for outdoor seating areas.

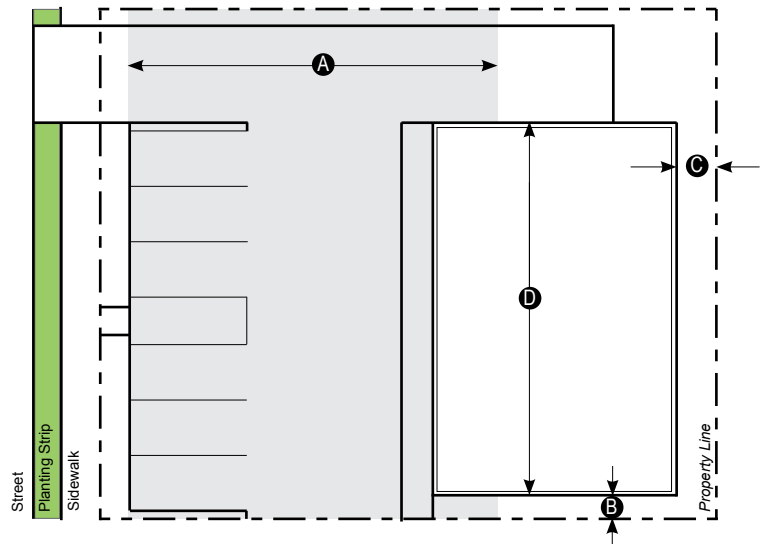

Site Plan



Principal Frontage - Elevation

# Section III: Design Standards

## Building Type - Civic Building

### Description

Inherently unique structures that are designed and constructed for community use or benefit by governmental, cultural, educational, public welfare, or religious organizations.

### General Provisions

- Building height shall be measured to the top of parapet or principal roof ridge from the average elevation of the front setback.
- Basements are not considered stories for the purpose of determining building height in stories.



### Bulk Standards

<b>A</b>	Build-to Zone <sup>1</sup>	5' Min - 80' Max
<b>B</b>	Side Setback (min)	5' min
<b>C</b>	Rear Setback (min)	Per base Zoning
<b>D</b>	Facade Width (min)	50% of buildable lot frontage; 50' Min if lot frontage > 100'
<b>E</b>	Building Height (max)	3 stories in 45'
<b>F</b>	First Floor Height (min)	One-story bldg: 16' Min Multi-story bldg: 14' Min
<b>G</b>	Upper Floor(s) Height (min)	10' floor-to-floor

<sup>1</sup>Exceptions may be made for up to 20' for outdoor seating areas.

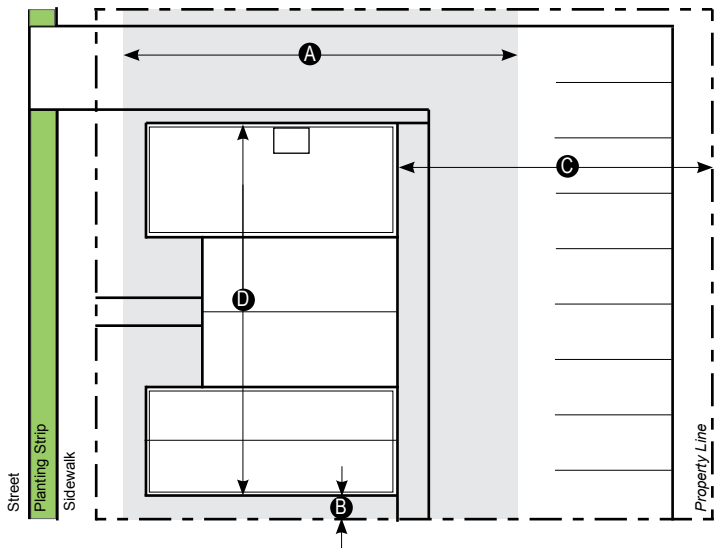

Site Plan

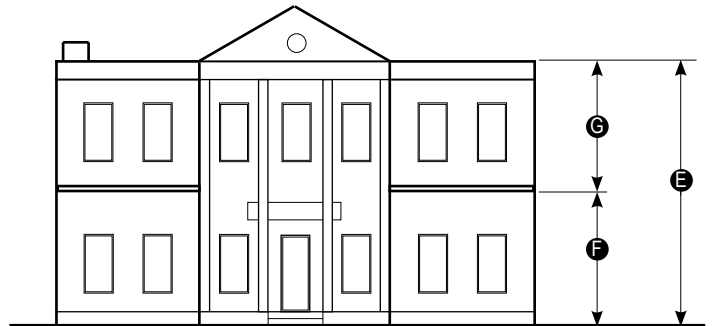

Principal Frontage - Elevation

# Section III: Design Standards

## Bulk Standards

### Base Zoning Clarifications

- All properties within the UDO shall be exempt from the Floor Area Ratio (FAR) requirements of the underlying base Zoning districts.
- All properties within the UDO shall be exempt from the Height Control Plane requirements of the underlying base Zoning districts (including Height Control Planes from adjacent residential districts).
- Impervious Surface Ratio is per the base Zoning district.

### Measurement of Height

- Building height shall be measured from each Street Frontage (excluding alleys) or Open Space.
- The height of a parking structure concealed by a building liner may be equal to the height of the liner, regardless of the number of stories. If there is no liner to conceal the parking structure, its height is limited by the maximum number of stories allowed.

### Active Use

- An active ground floor use requirement shall mean a habitable space occupied by retail, office, residential, institutional or recreational uses, specifically excluding parking and mechanical uses. Minimum 20 feet in depth.
- Active uses are those programmed spaces that generate pedestrian street activity and interaction. Hallways, storage rooms, fitness centers, and other ancillary spaces shall not qualify as an active use.
- An active use is required on the ground floor of all principal frontages.
- The term “active use” and ground level “building liner” are synonymous.
- Active ground floor uses must match the facade width percentage requirements. For example, if 50% facade width minimum is required along a lot’s frontage, then 50% minimum of the lot’s frontage must also consist of an active ground floor use.

### Build-to Zone

The Build-to Zone is the specified depth along a property’s street frontage(s) in which the required minimum facade width must be located. It is determined by the building type and specified as a range (minimum and maximum). The Build-to shall apply to all public streets.

- Depending on site conditions, the front of the Build-to Zone may begin at different locations.
  - When the existing streetscape and sidewalk meets with the *Major and Collector Street Plan*, the Build-to Zone begins at the back of the required streetscape (including sidewalk zones).
  - When the existing streetscape and sidewalk does not meet with the *Major and Collector Street Plan*, the sidewalk shall be widened on site and the Build-to Zone begins at the back of the new streetscape (including sidewalk zones).
  - When utility or pedestrian easements exist along the street frontage of a property, the Build-to Zone shall begin at the back of the easement.
  - When buildings front an Open Space, the Build-to Zone shall begin at the back of the Open Space.

### Facade Width

Facade width is the length of building facade that must be built within the build-to zone. The required facade width is determined by the building type and frontage type. The facade width standard shall apply to all Principal Frontages.

The minimum facade width is the minimum amount of the buildable lot frontage (excluding easements and required side setbacks) that must be defined by a building and is designated as a percentage of the buildable lot frontage. If a single lot frontage is greater than 100 feet, the required facade width may be reduced to a minimum of 50 feet in length.

When calculating the minimum facade width, access to structured parking shall be counted as part of the required facade width, and access to surface parking shall not be counted part of the required facade width. That is, access to surface parking is allowed in the “remaining” area, after the facade width requirement has been met.

# Section III: Design Standards

## Architectural Standards Table

	Residential: One- & Two-Family	Residential: Multifamily	Mixed-Use or Non-Residential	Civic
<b>Glazing</b> <sup>1,2</sup>	N/A		<b>Principal Frontage:</b> Ground Floor: 40% Upper Floors: 25%	
			<b>Minor Frontage:</b> Ground Floor: 25% Upper Floors: 15%	
<b>Materials</b>	On all public streets, structure must be built or clad with a durable and high finish material that does not terminate at the building corner. Material must wrap around the building corner a minimum of 10 feet.			

<sup>1</sup>Ground floor glazing facade area shall be measured from the finished ground floor elevation to the above finished floor elevation (or roof/parapet), but not to exceed 14 feet above the finished ground floor elevation.

<sup>2</sup>Upper floor glazing facade area shall be measured from finished floor elevation to finished floor elevation

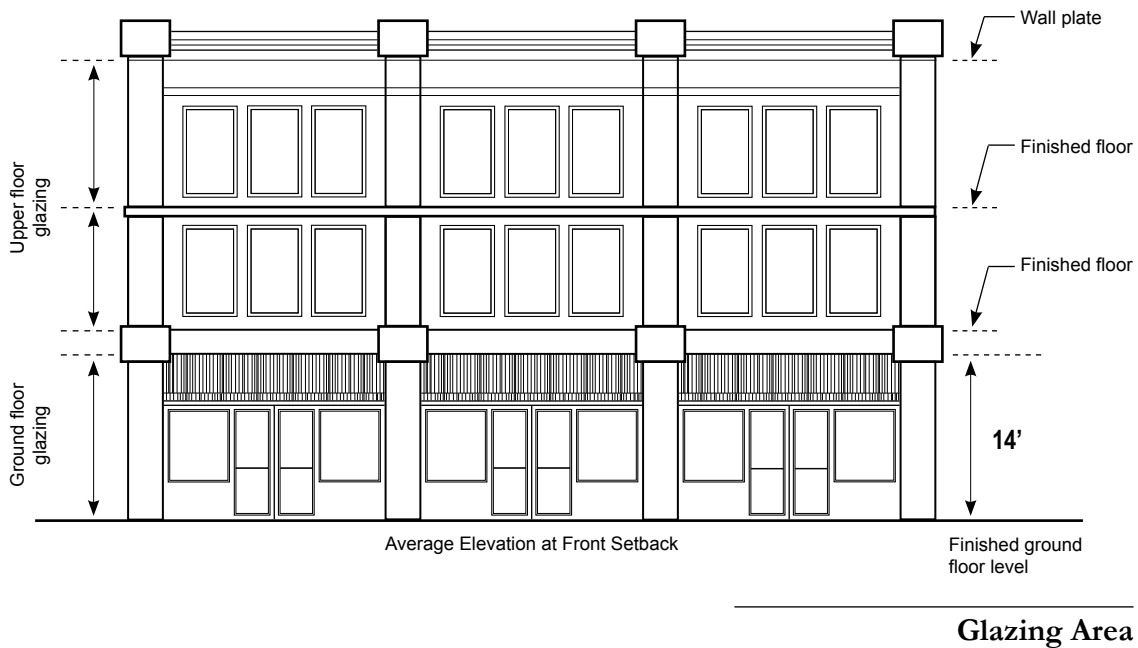

## Section III: Design Standards

### Architectural Standards

#### Glazing

Except as specifically referenced herein, facade glazing and opening standards shall include windows, doors and openings in parking structures and shall apply to all areas of the building facade facing a street or open space as follows:

- See Architectural Standards Table (page 23) for specific standards.
- Openings for vehicular access to parking structures on the first floor shall not be included in calculation of total facade area or glazed area.
- The UDO recognizes the need for building systems and functionality including interior mechanical systems, fire safety, et al, and their impact on building glazing. Areas of the facade affected by these elements *may* be exempt from the calculations, with Planning staff approval.
- All street and open space ground level exterior windows must have a minimum light transmission of 60 percent.

#### Massing

A building should avoid long, monotonous, uninterrupted walls or roof planes.

- Wall planes should not exceed 25 feet without a change in plane by means such as a vertical recess, projection, change in material or color, or plaster.
- Changes in roof planes should be in harmony with changes in wall planes.
- Changes in mass should be related to entrances, the integral structure or the organization of interior spaces and activities and not solely for cosmetic effect.

#### Materials

Building façades fronting a public street or open space must be clad with a durable and high finish material, including but not limited to: brick, brick veneer, stone, stucco, and hardy board. Hardy board shall be permitted above the ground floor only on public street frontages, and otherwise on all side and rear building façades.

The following facade materials are prohibited: E.I.F.S., plywood, plastics, unfinished concrete block, and vinyl siding.

#### Auto-oriented Canopies and Awnings

The design of auto-oriented canopies and awnings and their components shall be architecturally integrated with the main building using similar colors, materials, and architectural detailing.

Auto-oriented canopies and awnings, for uses such as drive-throughs and gas station pumps, shall not be considered the main building on the principal frontage but may be attached to a main building according to the following:

- Auto-oriented canopies and awnings shall be considered secondary to the main building. The main building shall comply with all frontage standards.
- The auto-oriented canopy and/or awning shall be located to the side or rear of the main building.
- The setback for the auto-oriented canopy and/or awning shall be a minimum of 10 feet from the front building facade.
- In cases of two principal frontages, exceptions may be made via modification.

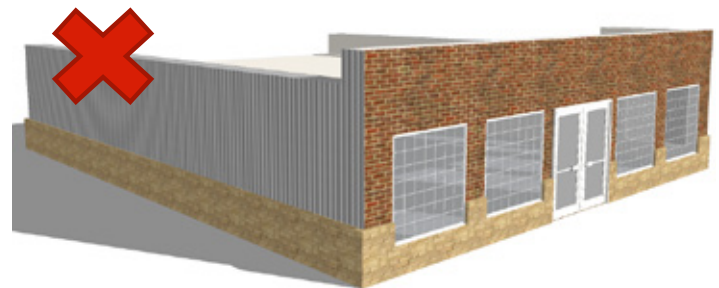
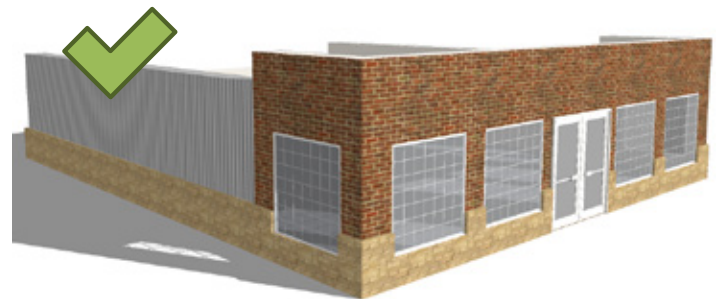

**Primary façade materials shall not change at outside corners and shall wrap the corner a minimum depth of 10 feet.**



# Section III: Design Standards

## Architectural Standards Cont'd

### Canopy

A horizontal cover, extending outward from a building, providing protection from the weather.

#### Design Standards

<b>A Clearance</b>	
Minimum from sidewalk	8'
Minimum with ROW encroachment	14'
<b>B Maximum projection</b>	within 2' of curb
<b>C Maximum canopy height</b>	4'

#### Notes

Canopies shall be constructed as a roof-like structure. Fabrics and non-rigid plastic are prohibited.

Encroachments in the public right-of-way must meet Metropolitan Government's current clearance standards and be approved under the mandatory referral process prior to installation.

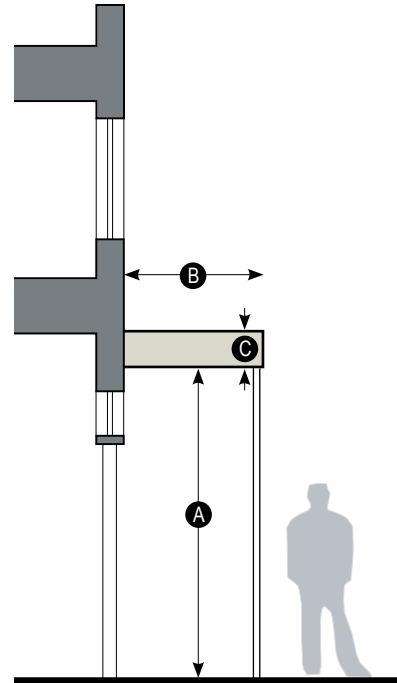

Section

### Awning

A wall-mounted, pitched cover extending from a building and providing protection from the weather.

#### Design Standards

<b>A Clearance</b>	
Minimum from sidewalk	8'
Minimum with ROW encroachment	14'
<b>B Maximum projection</b>	
First floor	4' from facade
Upper floors	2' from facade
<b>C Maximum awning height</b>	5'

#### Notes:

No awning shall exceed 25 feet in length.

Awnings shall not be constructed of materials that are glossy in finish.

Encroachments in the public right-of-way must meet Metropolitan Government's current clearance standards and be approved under the mandatory referral process prior to installation.

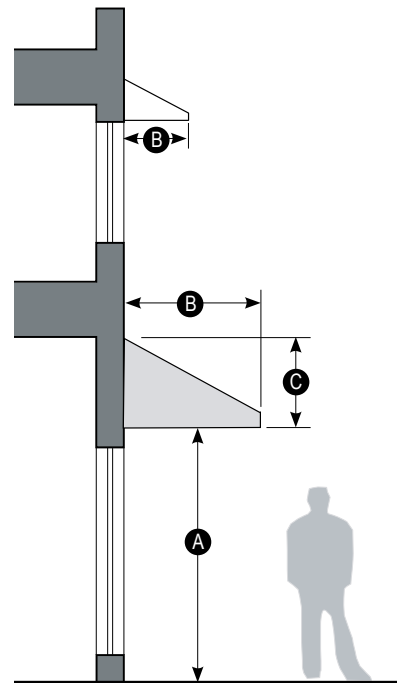

Section

# Section III: Design Standards

## Access and Parking Standards

### Parking Requirements

- Parking shall be provided in accordance with Metro Code Section 17.20.030 and Table 17.20.030.
- All properties within the UDO may utilize the UZO parking provisions of Metro Code Chapter 17.20.
- Shared parking areas may be used for properties within this UDO in accordance with Metro Code Section 17.20.100.

### Parking Location

- Where provided, off-street parking should be located behind, beside or beneath buildings, with the exception of one module of parking (two rows and a drive aisle) permitted within the front setback area between the building and right-of-way.
- For residential dwellings (one- & two-family only), no off-street parking area or loading area shall be located within the front setback area, unless it is located on a driveway.
- For residential dwellings (one- & two-family only), garages are to be located behind the principal structure front facade a minimum of 5 feet, whether detached or attached and recessed.
- Parking areas that accommodate 4 or more vehicles shall be separated from building facades a minimum of 8 feet.

### Vehicular/Pedestrian Conflict

Access points and on-site circulation shall be designed so that conflicts between pedestrians and vehicles are minimized.

### Pedestrian Access and Circulation

Safe and accessible walkways for pedestrians shall be provided in accordance with the following:

- On the principal frontage, a direct connection must be provided from the public sidewalk to the building's primary entrance.
- Pedestrian ways connecting to the main entrance of the building shall be incorporated into the design of surface parking lots.
- Interior sidewalks shall be a minimum of 5 feet wide.

### Vehicular Drop-off

Where driveways to parking facilities or drop-off areas cross the Sidewalk Corridor, priority shall be given to the pedestrian realm and the following design elements shall be required:

- The UDO and MCSP sidewalks and tree planting standards shall be maintained for any pedestrian islands created.
- Bollards or other protective devices shall be used to separate pedestrian and vehicular areas as needed.
- Distinction between vehicular lane and pedestrian areas shall be indicated through changes in grade, color, texture and/or material.

### Parking Structures

- Vehicular openings shall not exceed 35 feet in width, and shall have a minimum spacing of 35 feet.
- All parking structures with parking available to the public shall have a clearly marked pedestrian entrance, separate from vehicular access, on street frontages. A publicly accessible building lobby may meet this requirement.
- On Primary Streets, the ground floor of parking structures shall be located behind a liner building that is a minimum of 20 feet in depth.
- All parking structure facades visible from public right-of-ways must be designed with facade treatments/cladding that integrate or complement the architecture of the habitable portion of the building and the surrounding built context.

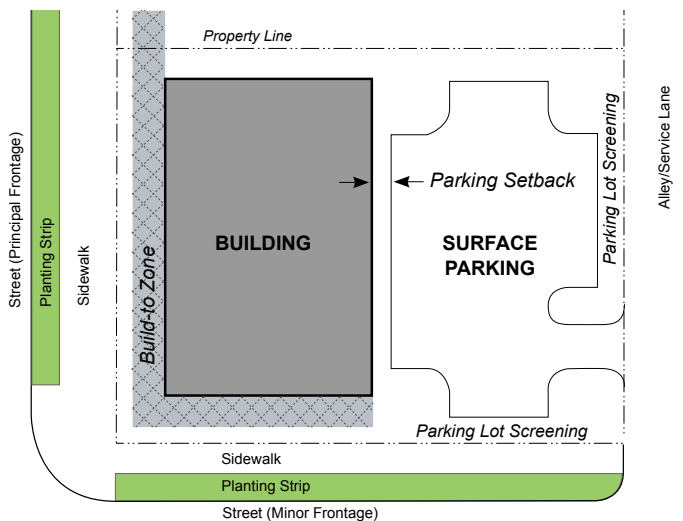

Surface Parking Location

## Section III: Design Standards

### Access and Parking Standards Cont'd

#### Cross Access and Joint Access

The provisions of Metro Code Section 17.20.170 shall apply with the following standards as a supplement.

Cross Access, which allows for vehicles to pass between properties without entering the public right-of-way, and/or Joint Access, a shared driveway providing access to multiple properties via one driveway, shall be required. An easement agreement which provides for the mutual right of ingress and egress for both property owners shall be recorded with the Register of Deeds and be referenced on a final plat and in any restrictive covenants, and shall be referenced on the site plan. Where possible, stub streets shall be built to adjacent property lines. Exceptions to the cross access and joint access provisions *may* be considered by minor modification due to existing conditions or circumstances of the subject property and/or adjacent properties.

#### Drive-Through Lanes

Queuing or stacking lanes used for areas such as drive-throughs shall be located to the side or rear of the main building.

If drive-throughs are located to the side of buildings, their width shall be limited to two lanes and the pick-up window shall be setback from the front building facade by a minimum of 10 feet. In no case shall drive-through facilities be located at the corner of two public streets.

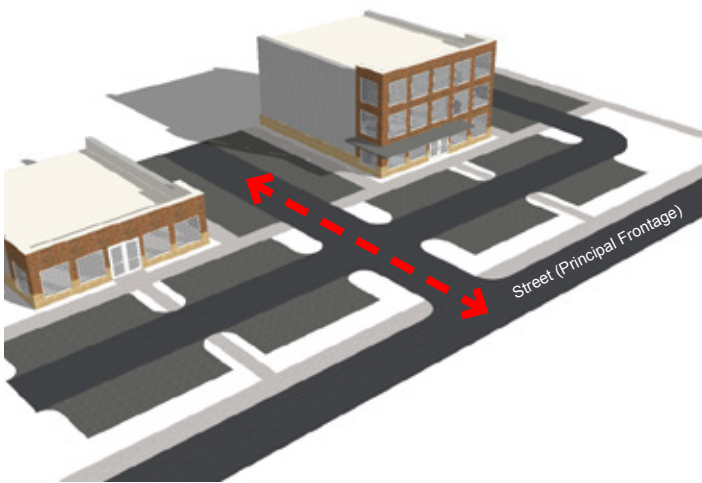

Joint Access: Properties share an access point creating a unified entrance/exit for multiple properties.



Cross Access: Properties utilize a shared connection between parking lots.

# Section III: Design Standards

## Landscaping and Screening Standards

### General Standards

Along property boundaries that coincide with the boundary of the UDO, the base Zoning District landscape buffer and screening standards shall apply, with the following exception:

- The abutting base zoning district boundary is a public street.

Tree and shrub species shall be chosen from the Urban Forestry Recommended and Prohibited Tree and Shrub List or an alternative species deemed appropriate by the Urban Forester. Low Impact Development strategies should be used for hardscaped areas, including parking areas and landscape islands, to maximize on-site infiltration of stormwater per Metro Low Impact Development Manual.

Parking area screening and landscaping standards shall apply to all surface parking lots including, but not limited to, public and private parking facilities, driveways and access aisles, the outdoor display of automobiles and other vehicles that are for sale or lease.

### Perimeter Landscaping for Surface Parking Lots

The following requirements shall apply to all surface parking lots that are larger than one thousand square feet:

- Parking areas and driveways adjacent to public streets and public open space shall be separated from the edge of the right-of-way by a perimeter landscape strip a minimum of 10 feet in width and planted with trees at a rate of one tree for every 30 feet of lot frontage
  - Perimeter landscaping strips that include a fence or wall may be reduced to 5 feet wide if the required trees are to be planted in tree islands located adjacent to the property lines.
- Parking areas shall be separated from adjacent side and rear lot lines by a perimeter landscape strip a minimum of 5 feet in width and planted with trees at a rate of one tree for every 50 feet.
- All perimeter landscape strips shall include evergreen shrubs and/or a fence or wall in accordance with the Fence and Wall Standards. Shrubs shall be a minimum of 2.5 feet in height at the time of installation.

### Interior Landscaping for Surface Parking Lots

For parking areas with more than ten thousand square feet in total area, at least eight percent of the gross area of the parking area shall be landscaped as follows:

- Interior planting areas are to be located within or adjacent to the parking area as tree islands, at the end of parking bays or inside eight foot wide or greater medians (where the median area is to be included as a part of the calculations for the interior planting area).
- One landscape island, a minimum 8 feet wide, is required for every 10 contiguous parking spaces.

Interior landscaping area shall be measured to include all parking spaces, drive aisles, and landscape islands.



### Landscaping for Surface Parking Lots

## Section III: Design Standards

### Landscaping and Screening Standards Cont'd

#### Service and Utility Areas

The following service and utility elements shall be located out of view from public streets, pedestrian corridors, and open spaces:

- All service areas (such as areas used for solid waste, recycling, grease traps, loading/receiving or maintenance) shall be located at the rear or side of the building beyond the frontage, and shall be screened to minimize sound and visibility from public streets, open space and adjacent properties.
- All utility equipment (such as HVAC and ventilation systems, meters and panels) shall not be allowed along the frontage of a public street and shall be located on the roof, to the rear or side of buildings, and otherwise visually screened from public streets and open space.

Service and utility areas shall be fully screened at all times. Screening for service and utility areas should be compatible with the style, materials, and colors of the principal building on the same lot. Screening for service and utility areas shall include vegetative materials and a fence or wall in accordance with the Fence and Wall Standards.

- Trees or shrubs (minimum of 2.5 feet in height at the time of installation) shall be evergreen and spaced to fully screen area.
- Vegetative material shall be located immediately adjacent to the element being screened in a planting area a minimum of four feet wide.

Note that in order to properly locate and screen mechanical equipment, approval may be subject to applicable Metro departments and agencies.



Service area screening

# Section III: Design Standards

## Landscaping and Screening Standards Cont'd

---

### Fences and Walls

#### Appearance

- Fences shall be installed so that the finished side faces outward and all bracing shall be on the inside of the fence.
- Fences and walls shall be constructed of any combination of brick, stone, masonry materials, treated wood, or metal.
- Chain-link fencing and razor wire shall not be permitted within the front setback area or between the building and public streets.
- Fences and walls used to screen refuse areas shall be opaque and include gates that prohibit unauthorized users to access the area

#### Standards by Location and Function

- Fences and walls located within the front setback area or between the building and public streets shall not exceed 4 feet in height. Fences greater than 2.5 feet in height shall be a minimum of 30 percent transparent to allow visibility into the property.
- The height of fences and walls along a sidewalk shall be measured from sidewalk grade.
- Fences and walls along rear lot lines, behind a principal building, and along side property lines not fronting a public street shall not exceed 8 feet in height.
- Fences and walls used to screen parking shall be a minimum of 2.5 feet above the grade of the parking lot. When a fence or wall is combined with plantings, the majority of the plantings shall be between the right-of-way and the fence or wall.
- Fences and walls used to screen service and utility areas shall be a minimum of 16 inches taller than the element being screened.

#### Parapet Walls or Integrated Building Elements

Parapet walls or integrated building elements (such as knee walls, alcoves, wing walls, roof extensions, etc.) may also be used to enclose site features required to be screened.

# Section IV: Sign Standards

Administration  
General Requirements  
Permitted Sign Types

# Section IV: Sign Standards

## Administration

---

### Intent

The Signage Standards of this UDO allow each business to communicate its message clearly without detracting from the envisioned visual character of the area. Signage should be attractive, appropriately scaled, and contribute positively to the surroundings without producing visual clutter.

### Applicability

These sign regulations shall not apply to single- & two-family zoning districts in the Clarksville Pike UDO.

Base district standards that are not varied by the provisions set forth in this section shall apply within the Clarksville Pike UDO. In addition to the standards set forth within this section, the following Sections of the Metro Zoning Code shall apply to all regulated signage within the Clarksville Pike UDO.

- Section 17.04.06 - Definitions of general terms
- Within Chapter 17.32 SIGN REGULATIONS:
  - Section 17.32.020 - General Provisions
  - Section 17.32.040 - Signs allowed without a permit
  - Section 17.32.050 - Prohibited signs
  - Section 17.32.060 - Permitted on-premises temporary signs
  - Section 17.32.145 - Landmark signs
  - Section 17.32.160 - Computations

### Right-of-way Encroachments

Where a sign is proposed to encroach into the public right-of-way, an application shall be made with the Public Works Department. The application shall include the requirements of the Public Works Department available at their website: <http://www.nashville.gov/public-works/permits.aspx>, in addition to the submittal requirements for sign permit applications in the Metro Zoning Code.

### Nonconforming Signs

Applicable provisions (Sections 17.40.660 and 17.40.690) of the Metro Zoning Code apply.

In addition, panel changes in a legally non-conforming cabinet sign shall be permitted. All new panels shall conform to all illumination standards herein.

### Prohibited Signs

In addition to signs prohibited in the base zoning district, on-premise temporary signs, pole mounted signs, and billboards shall not be permitted. Any sign which has any visible moving part, flashing or osculating lights, visible mechanical movement of any description, or other apparent visible movement achieved by any means are prohibited. Digital signs are prohibited.

### Other Sign Types

Auto-oriented canopy/awning signs: The allocation of signage for auto-oriented canopies and awnings shall be measured as wall signs and shall only be used on the canopy/awning. The following standards shall apply:

- Only one sign shall be permitted on each side of a canopy/awning which faces a public ROW.
- Internal illumination shall be permitted only in the sign area.



# Section IV: Sign Standards

## General Requirements

### Placement of Signs

Signs other than those on windows, shall be placed so as not to obscure key architectural features or door or window openings. No sign shall extend above the eave line or parapet of the principal building(s) on the lot.

### Materials

All permanent, on-premises signs shall be constructed of a rigid, weatherable material such as hard plastic, wood, MDO plywood, aluminum, steel, PVC, glass and/or Plexiglas. On-premises, permanent signs shall not be constructed of nonrigid materials including, but not limited to, vinyl, fabric, canvas, or corrugated plastic. The provisions of this subsection shall not apply to approved, permitted canopies, awnings, and porticoes.

### Illumination

Lighted signs shall be either spotlighted, externally lit, or back-lit with a diffused light source. Lighting sources shall be directed and shielded so that they do not produce glare off the site or on any object other than the sign. Bulbs should not be visible.

Internal lighting shall be permitted to illuminate letters and logotype only. Sign backgrounds shall be opaque.

Neon Lights are permitted as accents if they form the lettering on a sign and/or they are used to define a logo or border.

Portions of signs with manual changeable copy may be internally lit to illuminate the background of the sign.

Transformers and other mechanical equipment related to sign illumination shall be located inside the building or otherwise concealed from public view.

Exposed raceways must be finished to match or complement the sign or the building surface on which the sign is mounted.

### Maximum Aggregate Building Signage

The maximum aggregate amount of display surface area of all permanent on-premise building signage permitted on a given building facade facing a street or parking lot, shall not exceed 15% of the building facade area. Facade area is calculated by multiplying the ground floor building facade length by a height of 14 feet.

A maximum of one ground sign is permitted per 200 feet of street frontage.

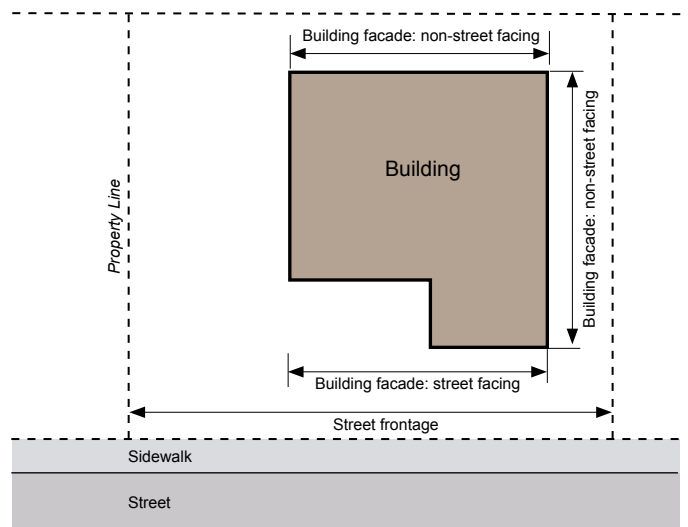

**Building facade and street frontage measurement**

## Section IV: Sign Standards

### Permitted Sign Types



#### Building Signage

**Awning Sign:** A building sign that includes graphics or symbols that are painted, sewn, or otherwise adhered to the awning material as an integrated part of the awning itself.

**Canopy Sign:** A building sign that is attached above, below or to the face of a canopy.

**Projecting Sign:** A building sign that projects outward from the facade, typically at a ninety degree angle. Projecting signs are typically, but not always, vertically oriented and generally mounted above the first floor.

**Shingle Sign:** A smaller building sign that projects outward, typically at a ninety degree angle, and hangs from a bracket or support that is located over or near a building entrance.

**Wall Sign:** A building sign that is attached flat to, or mounted away from but parallel to, the building facade. A wall sign may be painted on the building facade.

**Window Sign:** Any sign attached to or directly applied on a window or glass door and intended for viewing from the exterior.

#### Ground Signage

**Monument Sign:** A low lying ground sign that is attached along its entire length to a continuous pedestal.

## Section IV: Sign Standards



## Section IV: Sign Standards

### Building Sign - Awning

#### Description

An awning sign is a type of building sign. Graphics and symbols are painted, sewn, or otherwise adhered to the awning material as an integrated part of the awning itself.

#### General Provisions

- Only awnings on the first story may contain signs.
- A maximum of one sign is permitted per awning surface.
- A maximum of two awning surfaces may contain signs.
- The name and logo of the establishment are the only signs permitted on awnings.
- An awning sign shall not be internally illuminated.

#### Design Standards

<b>A</b>	Sloping plane sign area (max)	25% of surface area
<b>B</b>	Valance sign area (max)	50% of surface area
<b>C</b>	Valance sign width (max)	75% of valance width
<b>D</b>	Height of text and graphics on valance (max)	2 feet
<b>E</b>	Vertical clearance from sidewalk grade, excluding valance (min)	8 feet (12 feet with ROW encroachment)

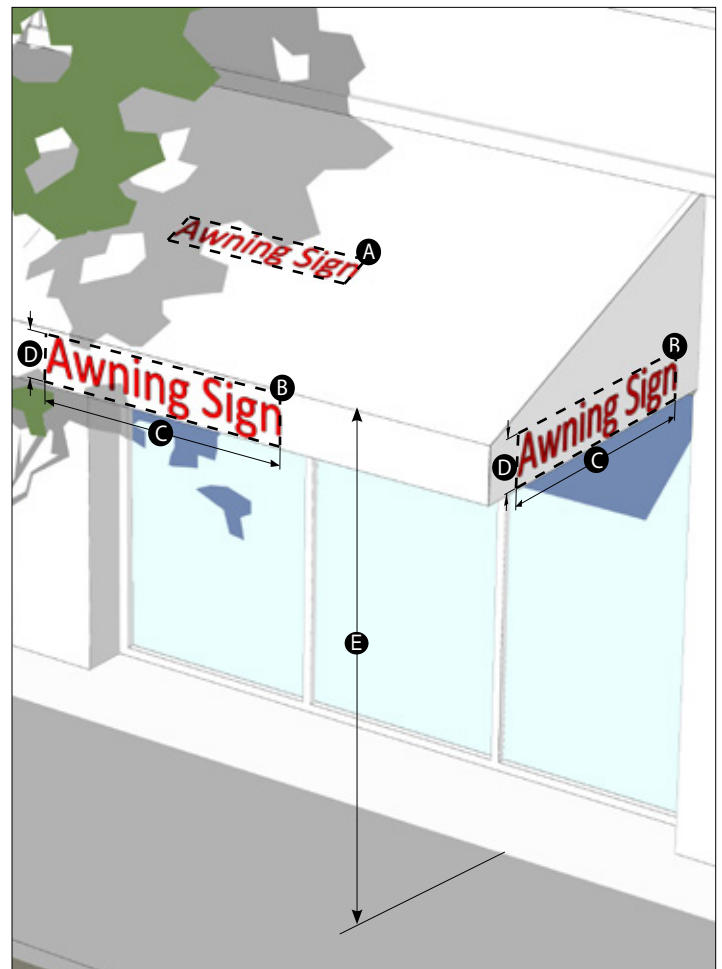

# Section IV: Sign Standards

## Building Sign - Canopy

### Description

A canopy sign is a type of building sign that is attached above, below or to the face of a canopy.

### General Provisions

- A canopy sign cannot extend outside the overall length or width of the canopy. However, a canopy sign may extend above or below the canopy provided the sign meets all other design standards.
- Maximum of one sign per canopy.
- Raceways are permitted for signs extending below or above the canopy.
- A canopy sign can be externally or internally illuminated in accordance with page 33.
- Cabinet signs are not permitted as canopy signs.
- This definition does not include freestanding canopies over fuel pumps. See the Auto-oriented canopy/awning signs on page 32.

### Design Standards

<b>A</b>	Sign area (max)	5% of the Facade Area or a maximum of 64 SF for single story and 84 SF for multi-story, whichever is less
<b>B</b>	Sign Width (max)	75% of canopy length
<b>C</b>	Height of text and graphics (max)	2 feet
<b>D</b>	Exposed Raceway height (max)	50% of the letter height, OR if the Raceway is used as the sign background, the Raceway may extend 3 inches beyond the largest part of the sign.
<b>E</b>	Vertical clearance from sidewalk grade (min)	8 feet (12 feet with ROW encroachment)

Refer to the Illumination section (pages 33) for additional raceways standards and permitted locations.



# Section IV: Sign Standards

## Building Sign - Projecting

### Description

A projecting sign is a type of building sign that projects outward from the facade, typically at a ninety degree angle. Projecting signs are typically, but not always, vertically oriented and generally mounted above the first floor.

### General Provisions

- A projecting sign must be located at least 25 feet from any other projecting sign. When building width prohibits adherence to this standard, flexibility shall be permitted though a Minor Modification to be reviewed by staff.
- A projecting sign may be erected on a building corner when the building corner adjoins the intersection of two streets. Allocation of sign area from both streets may be used, however, in no case shall the sign exceed the maximum dimensional standards below.
- A projecting sign can be externally or internally illuminated in accordance with pages 33.



### Design Standards

<b>A</b>	Sign area (max)	20 SF
<b>B</b>	Height (max)	1 foot below bottom eave line or top of parapet
<b>C</b>	Projection Width (max)	4 feet
<b>D</b>	Vertical clearance from sidewalk grade (min)	8 feet (12 feet with ROW encroachment)

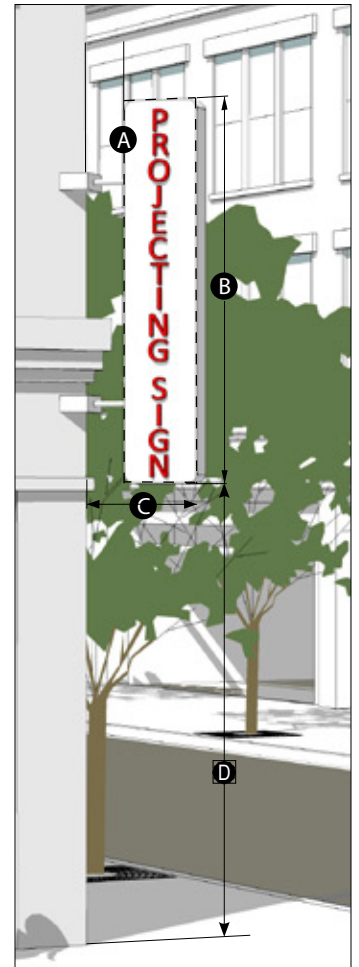
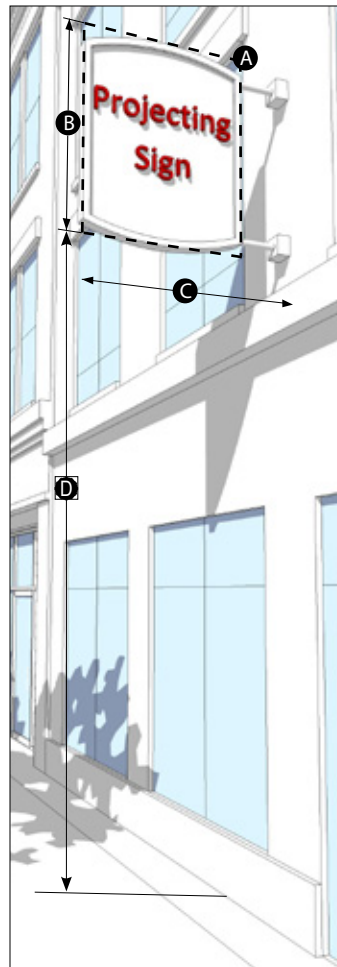

## Section IV: Sign Standards

### Building Sign - Shingle

#### Description

A shingle sign is a smaller building sign that projects outward, typically at a ninety degree angle, and hangs from a bracket or support that is located over or near a building entrance. These signs are pedestrian scaled, and easily read from both sides.

#### General Provisions

- Sign shall be located within 8 feet of an active pedestrian building entrance. This does not include service entries or entries that primarily remain locked.
- An active pedestrian entrance at the corner of a building is allowed signs on both streets.
- A shingle sign shall be located below the window sills of the second story.
- A shingle sign shall not be internally illuminated.



#### Design Standards

<b>A</b>	Sign area (max)	9 square feet
<b>B</b>	Height (max)	3 feet
<b>C</b>	Width (max)	3 feet
<b>D</b>	Vertical clearance from sidewalk grade (min)	8 feet (12 feet with ROW encroachment)



# Section IV: Sign Standards

## Building Sign - Wall

### Description

A wall sign is a building sign that is attached flat to, or mounted away from but parallel to, the building facade.

A wall sign may be painted on the building facade. Wall signs are typically intended to be seen from a distance and are often accompanied by additional pedestrian-scaled signage.

### General Provisions

- A wall sign shall either be located lower than the window sills of the second story or at the top of the building, not to be placed below the windows of the highest floor.
- No portion of a wall sign may extend above the roof line or parapet wall of a building with a flat roof, or above the lower eave line of a building with a pitched roof.
- A wall sign shall not cover windows or architectural details.
- An exposed raceway shall be finished to match the background wall or be integrated into the overall design of the sign.
- A wall sign can be externally or internally illuminated in accordance with pages 33.



### Design Standards

A	Sign area (max)	5% of the Facade Area or a maximum of 48 SF for single story building and 64 SF for multi-story buildings, whichever is less
B	Projection from wall (max)	12 inches
C	Exposed Raceway height (max)	50% of the letter height, OR if the Raceway is used as the sign background, the Raceway may extend 3 inches beyond the largest part of the sign.
Refer to the Illumination section (pages 33) for additional raceways standards and permitted locations.		





## Section IV: Sign Standards

### Building Sign - Window

#### Description

A window sign is a building sign that is attached to, placed upon, printed on the interior or exterior of a window or door of a building, or displayed within one foot of the interior of a window, and is clearly intended for public recognition outside the building.

#### General Provisions

- Only openings on the first story may contain window signs.
- Window signs attached to or directly applied on glass shall be placed between 2 feet and 8 feet above the sidewalk grade.
- Window signs attached to or directly applied on glass shall have a clear background, and shall not be illuminated.
- Window signs displayed within one foot of the interior of a window shall have a clear background, and can be internally lit to illuminate letters and logotype only.

#### Design Standards

<b>A</b>	Sign area (max)	15 SF
<b>B</b>	Height (max)	3 feet
<b>C</b>	Width (max)	5 feet



# Section IV: Sign Standards

## Ground Sign - Monument

### Description

A monument sign is a type of ground sign that is attached along its entire length to a continuous pedestal.

### General Provisions

- A maximum of one ground sign is permitted per 200 feet of street frontage.
- A monument sign must be set back at least 5 feet from property lines.
- A sign erected on the top of a retaining wall is required to meet the standards for a monument sign. The height of the wall shall be included in the overall height calculation. In this case, the 5 foot minimum setback is not required.
- A sign affixed to the face of a retaining wall or seat wall that is an integral part of a plaza or streetscape design may utilize the sign area allocated to Wall Signs. In this case, the 5 foot minimum setback is not required.
- A monument sign can be externally or internally illuminated in accordance with page 33.



### Design Standards

A	Sign area (max per sign)	<b>Single Tenant:</b> 28 SF <b>Multi-Tenant:</b> 48 SF
B	Height (max)	<b>Single Tenant:</b> 5 feet; 2.5 feet for any part of sign within 15 feet of a driveway. <b>Multi-Tenant:</b> 7 feet



This page left intentionally blank

